



Global Power Electronics Company

iMASTER U1

Powerful Micro Drive

AD Advanced Drive Technology
motor control & power conversion

www.adtech21.com

56 Beolmal-ro, Dongan-gu, Anyang-si, Gyeonggi-do, 14059, Korea
TEL : 82-31-459-5051 FAX : 82-31-459-5053



Specifications of the product are subject to change without notice for quality improvement.

Printed in Korea

AD Advanced Drive Technology
motor control & power conversion

Toughness & Easy to Use + General Purpose

Design Simple & Stylish appearance

Compact Minimize the space

Operation Easy Installation & Simple Operation



Applications
Suit for various machines

Supreme Performance

- User Friendly
- Built in PID function
- Traverse Operation

Powerful Torque

- V/F Control
- Sensorless Vector Control
- Powerful torque at low speed (150% @ 1Hz)

High Reliability

- Global Standard ; UL, CE, RoHS
- Conformal coating of internal PC board for harsh environment

Food. Mixer

Fan. Pump

Wood machine

Conveyor



■ Adoption of optimal algorithm to minimize the motor loss

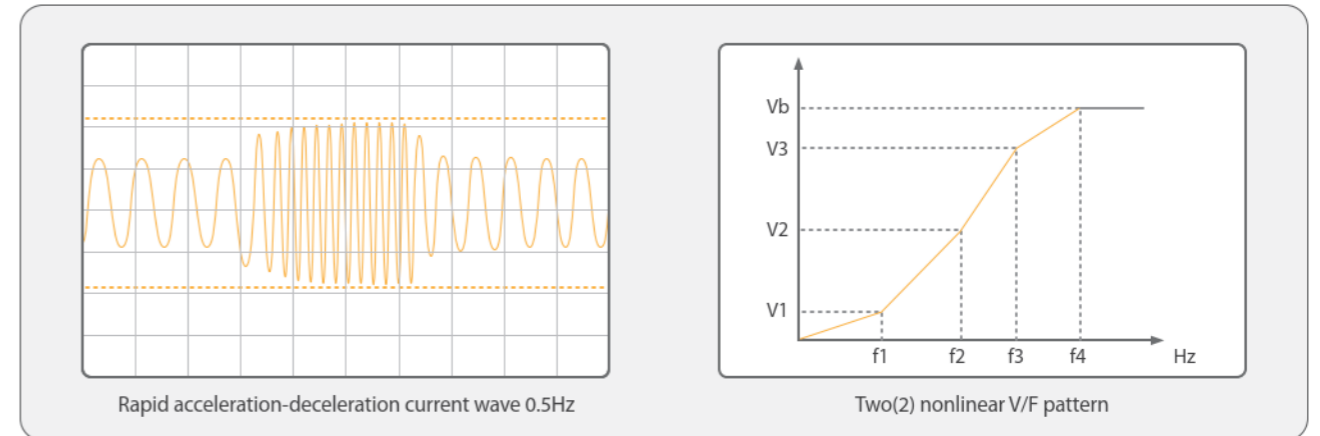

■ Standard RS-485 communication



■ Built in PID control

PID function is enable to temperature, flow or pressure control by proportional action(P), integral action(I) and derivative action(D) to reduce the difference between actual and target value.

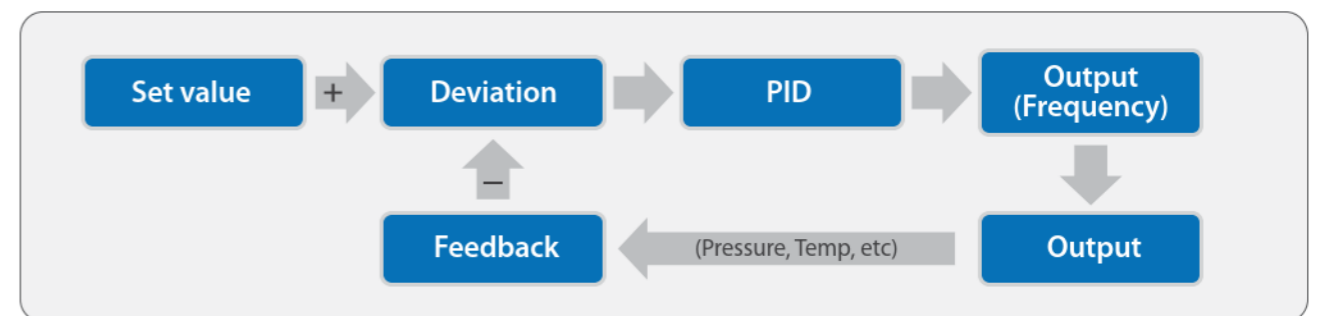

■ Various Functions

- Analog Input (0~10V, 4~20mA)
- Multi step operation (16 step)
- Jog operation

■ Global Standard



Product range

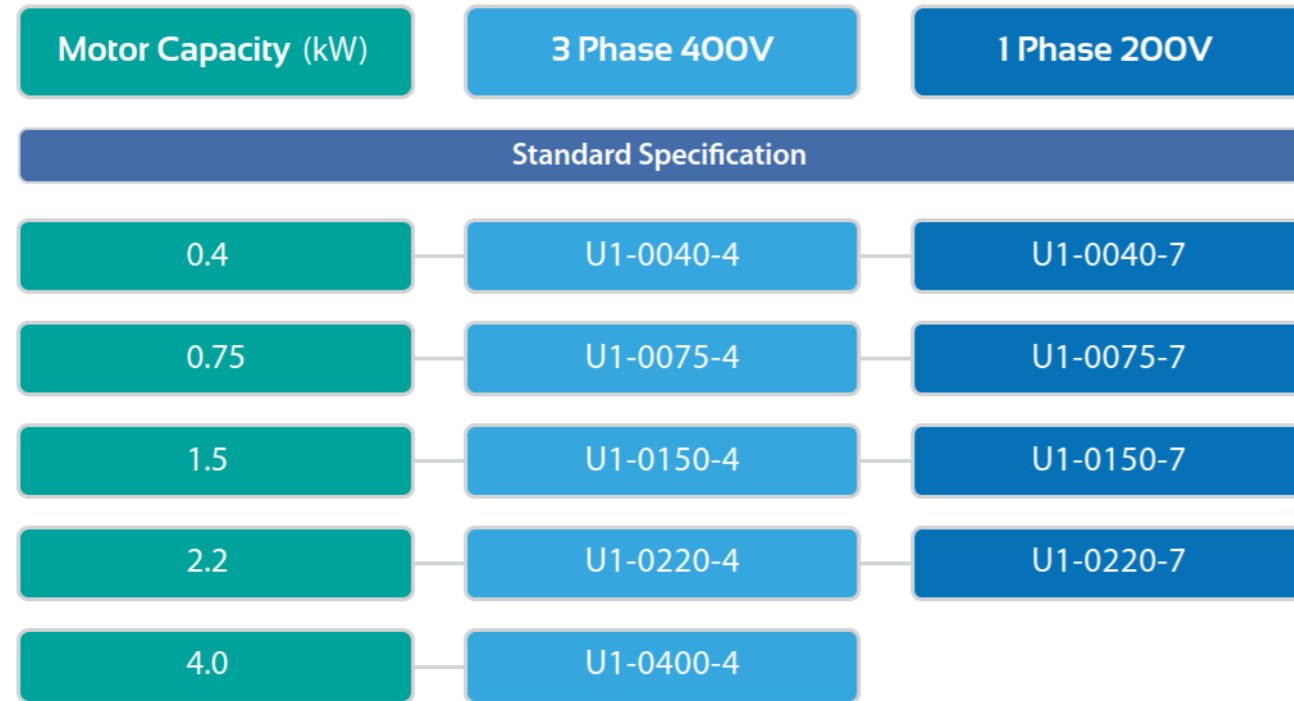

Model Name

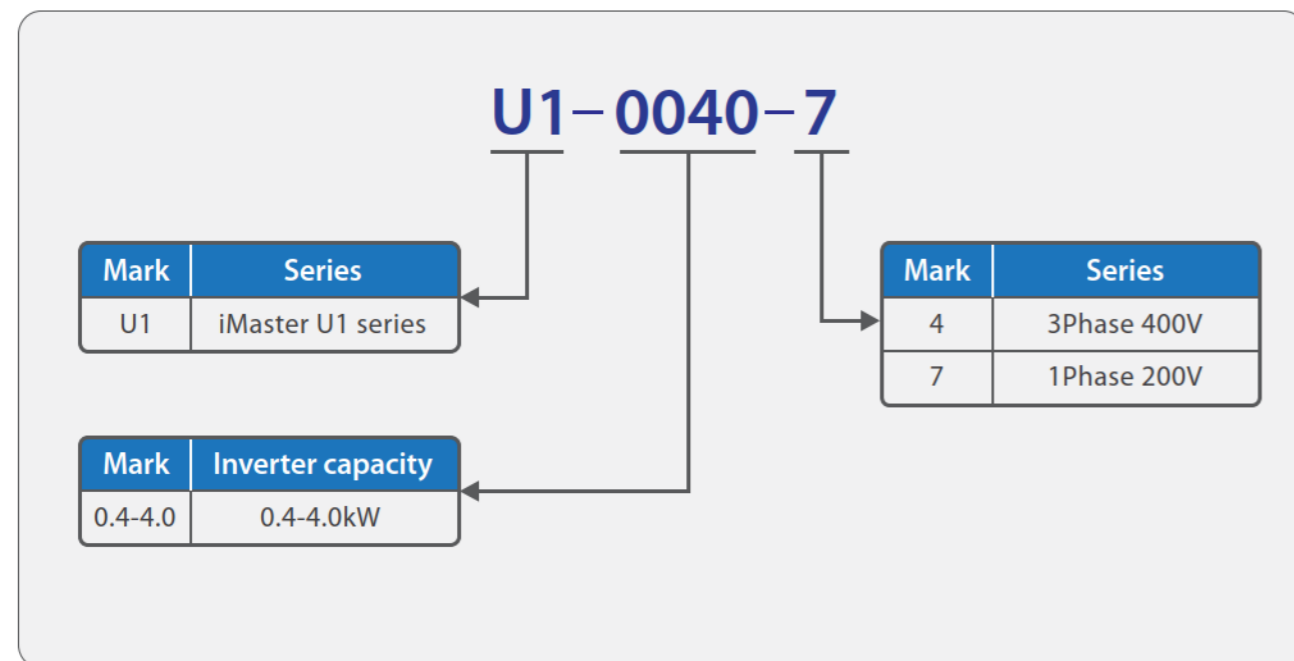

3 Phase 400V

Item	Specification					
Type (U1-□□□□-4)	U1-0040-4	U1-0075-4	U1-0150-4	U1-0220-4	U1-0400-4	
Applicable Motor [kW]	0.4	0.75	1.5	2.2	4.0	
Rated Output	Rated Voltage [V]	3 Phase 380V ~ 480V (with AVR function)				
	Rated Current [A]	1.8	2.5	4.3	6.3	10.5
	Overload Capacity	150% @ rated output frequency - 1 min. 200% @ rated output frequency - 0.5 sec.				
Rated Input	Rated Frequency (Fluctuation)	0.01~400Hz				
	Available Voltage [V]	3 Phase 380V (-15%) ~ 480V (+10%)				
	Frequency [Hz]	50/60Hz (Fluctuation : ±5%)				
	Input Current [A]	1.7	3.1	5.9	8.2	13
Braking Transistor	Built in					
Protection Degree	IP20 (IEC 60529)					
Cooling Method	Natural		Forced			
Weight (kg)	0.8	0.8	0.9	0.9	1.3	

1 Phase 200V

Item	Specification				
Type (U1-□□□□-7)	U1-0040-7	U1-0075-7	U1-0150-7	U1-0220-7	
Applicable Motor [kW]	0.4	0.75	1.5	2.2	
Rated Output	Rated Voltage [V]	3 Phase 200V ~ 240V (with AVR function)			
	Rated Current [A]	3.5	4.2	9.2	10
	Overload Capacity	150% @ rated output frequency - 1 min. 200% @ rated output frequency - 0.5 sec.			
Rated Input	Rated Frequency (Fluctuation)	50/60 Hz (Fluctuation 5%) 0.01 ~ 400Hz			
	Available Voltage [V]	1 Phase 200V (-10%) ~ 240V (+10%)			
	Frequency [Hz]	50/60Hz (Min. 47 ~ Max. 63Hz)			
	Input Current [A]	5.4	9.7	16.4	24
Braking Transistor	Built in				
Protection Degree	IP20 (IEC 60529)				
Cooling Method	Forced				
Weight (kg)	0.6	0.6	1.0	1.0	

■ Dimension

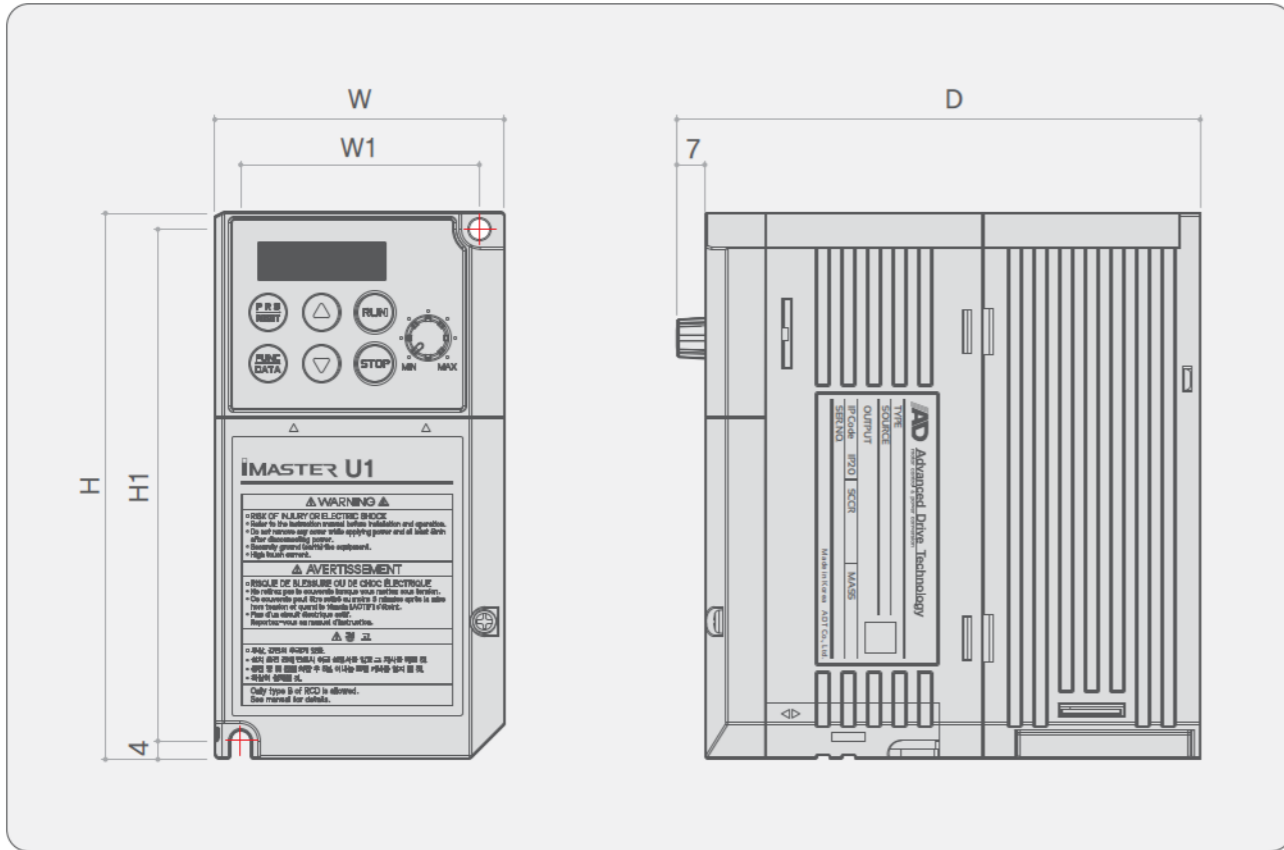

Applicable Motor [kW]	Model	Frame	W(mm)	W1(mm)	H(mm)	H1(mm)	D(mm)
3-Phase 400V	0.4	U1-0040-4	108	96	128	120	146
	0.75	U1-0075-4					
	1.5	U1-0150-4					
	2.2	U1-0220-4					
Single-Phase 200V	0.4	U1-0040-7	68	56	128	120	123
	0.75	U1-0075-7					
	1.5	U1-0150-7	108	96	128	120	146
	2.2	U1-0220-7					

■ Connection Diagram

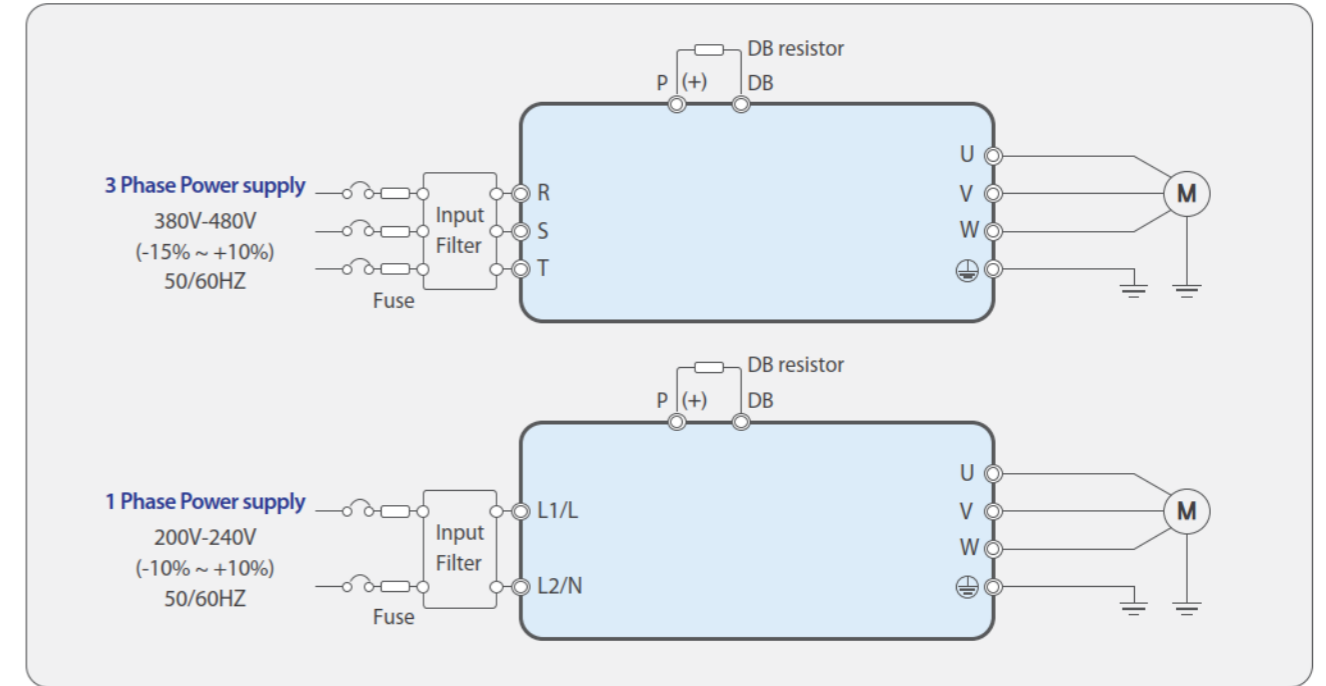

■ Wiring Diagram

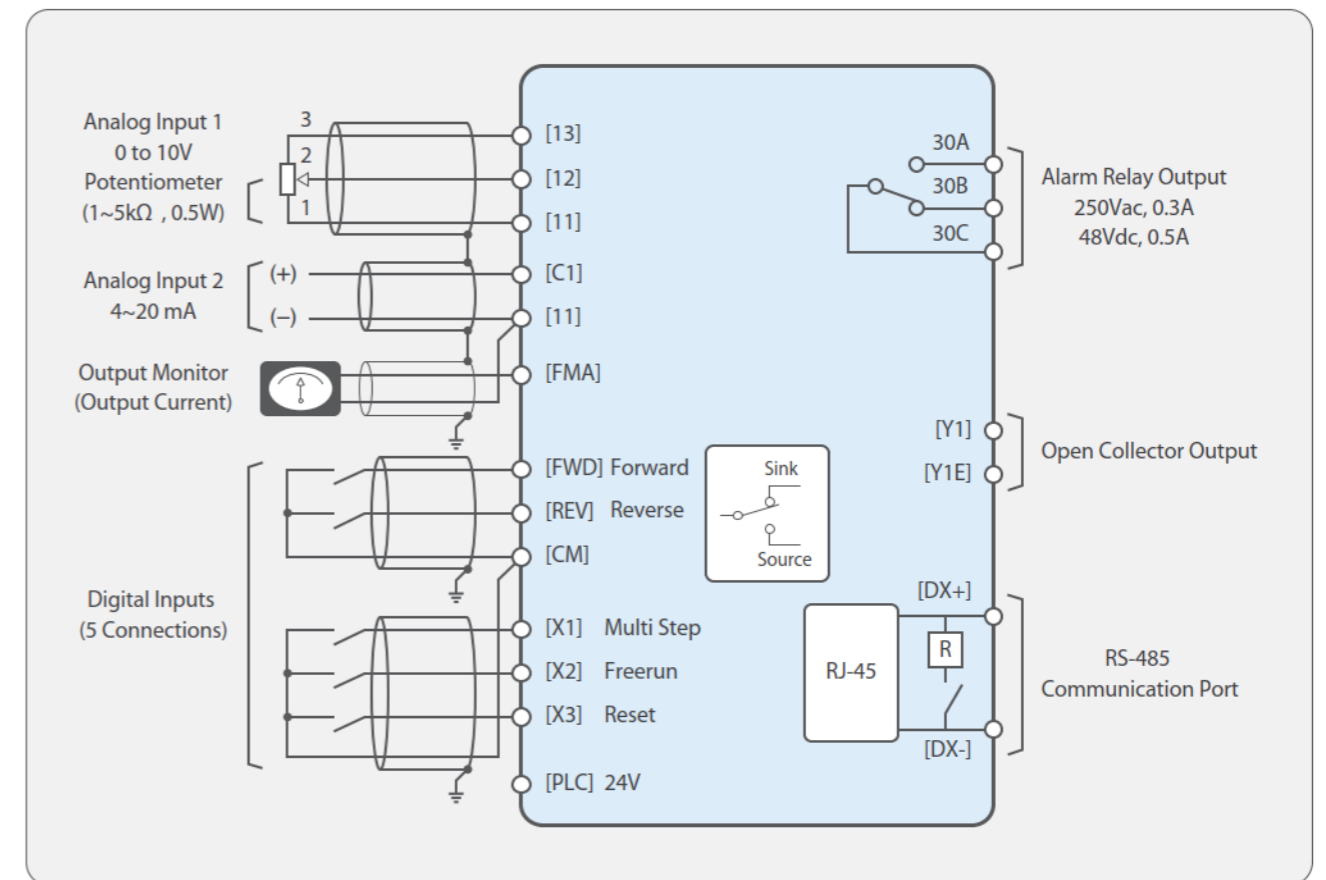



Advanced simple Inverter

iMaster-U1

CAUTION

Thank you for purchasing our iMaster-U1 of inverters.

- This product is designed to drive a three-phase induction motor. Read through this instruction manual and be familiar with the handling procedure for correct use.
- Improper handling might result in incorrect operation, a short life, or even a failure of this product as well as the motor.
- Deliver this quick guide to the end user of this product. Keep this in a safe place until this product is discarded.
- For more details, refer to the instruction manual on website. (www.adtech21.com)
- ADT Co. Ltd.

56 Beolmalro, Dongangu, Anyangshi, Kyunggido, 14059 Korea



Phone : +82-31-459-5051

Fax : +82-31-459-5053

Safety precautions



Read this manual thoroughly before proceeding with installation, connections (wiring), operation, or maintenance and inspection. Ensure you have sound knowledge of the device and familiarize yourself with all safety information and precautions before proceeding to operate the inverter.

Safety precautions are classified into the following two categories in this manual.

 WARNING	Failure to heed the information indicated by this symbol may lead to dangerous conditions, possibly resulting in death or serious bodily injuries.
 CAUTION	Failure to heed the information indicated by this symbol may lead to dangerous conditions, possibly resulting in minor or light bodily injuries and/or substantial property damage.

Failure to heed the information contained under the CAUTION title can also result in serious consequences. These safety precautions are of utmost importance and must be observed at all times.

Operation

 WARNING 
<ul style="list-style-type: none">• Be sure to install the terminal block cover before turning the power on. Do not remove the cover while power is applied. Otherwise electric shock could occur.• Do not operate switches with wet hands. Doing so could cause electric shock.• If the retry function has been selected, the inverter may automatically restart and drive the motor depending on the cause of tripping. (Design the machinery or equipment so that human safety is ensured after restarting.)• If the stall prevention function (current limiter), automatic deceleration, and overload prevention control have been selected, the inverter may operate at an acceleration /deceleration time or frequency different from the set ones. Design the machine so that safety is ensured even in such cases. Otherwise an accident could occur.• The STOP key is only effective when function setting (Function code F02) is established to enable the STOP key. Prepare an emergency stop switch separately. If you disable the STOP key priority function and enable operation by external commands, you cannot emergency-stop the inverter using the STOP key on the built-in keypad.• If an alarm reset is made with the operation signal turned on, a sudden start will occur. Ensure that the operation signal is turned off in advance. Otherwise an accident could occur.

1. Operating Environment

Install the inverter in an environment that satisfies the requirements listed in

Table 1.1 Environmental Requirements

Item	Specifications
Site location	Indoors
Ambient temperature	-10 to +50°C (IP20) (Note 1)
Relative humidity	5 to 95% (No condensation)
Atmosphere	The inverter must not be exposed to dust, direct sunlight, corrosive gases, flammable gas, oil mist, vapor or water drops. (Note 2) The atmosphere can contain only a low level of salt. (0.01 mg/cm ² or less per year) The inverter must not be subjected to sudden changes in temperature that will cause condensation to form.
Altitude	1,000 m max. (Note 3)
Atmospheric pressure	86 to 106 kPa
Vibration	3 mm (Max. amplitude) 2 to less than 9 Hz 9.8 m/s ² 9 to less than 20 Hz 2 m/s ² 20 to less than 55 Hz 1 m/s ² 55 to less than 200 Hz

Table 1.2 Output Current Derating Factor in Relation to Altitude

Altitude	Output current derating factor
1000 m or lower	1.00
1000 to 1500 m	0.97
1500 to 2000 m	0.95
2000 to 2500 m	0.91
2500 to 3000 m	0.88

(Note 1) When inverters are mounted side-by-side without any gap between them, the ambient temperature should be within the range from -10 to +40°C.

(Note 2) Do not install the inverter in an environment where it may be exposed to cotton waste or moist dust or dirt which will clog the heat sink in the inverter. If the inverter is to be used in such an environment, install it in the panel of your system or other dustproof containers.

(Note 3) If you use the inverter in an altitude above 1000 m, you should apply an output current derating factor as listed in Table 2.2.

2. Installing the Inverter

(1) Mounting base

The temperature of the heat sink may rise up to approx. 90°C during operation of the inverter, so the inverter should be mounted on a base made of material that can withstand temperatures of this level.



WARNING

Install the inverter on a base made of metal or other non-flammable material.

A fire may result with other material.

(2) Clearances

Ensure that the minimum clearances indicated in Figure 2.1 are maintained at all times. When installing the inverter in the panel of your system, take extra care with ventilation inside the panel as the temperature around the inverter tends to increase.

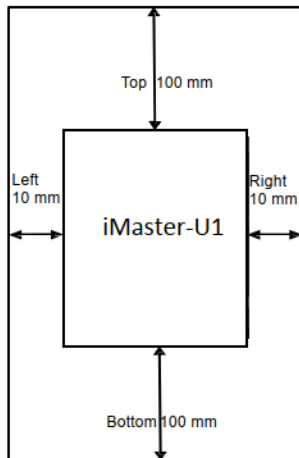

Figure 2.1 Mounting Direction and Required Clearances

When mounting two or more inverters

When mounting two or more inverters in the same unit or panel, basically lay them out side by side. As long as the ambient temperature is 40°C or lower, inverters can be mounted side by side without any clearance between them. When the inverters necessarily mounted one above the other be sure to separate them with a partition plate or the like so that any heat radiating from an inverter will not affect the one(s) above.

(3) Mounting direction

Secure the inverter to the mounting base with four screws or bolts (M4) so that the iMaster-U1 logo faces outwards. Tighten those screws or bolts perpendicular to the mounting base.

Note Do not mount the inverter upside down or horizontally. Doing so will reduce the heat dissipation efficiency of the inverter and cause the overheat protection function to operate, so the inverter will not run.

CAUTION

Prevent lint, paper fibers, sawdust, dust, metallic chips, or other foreign materials from getting into the inverter or from accumulating on the heat sink.

This may result in a fire or accident.

3. Wiring

Follow the procedure below. (In the following description, the inverter has already been installed.)

3.1 Removing and mounting the terminal block covers

- (1) Loosen the screw securing the control circuit terminal block cover.
- (2) Insert your finger in the cutout (near "PULL") in the bottom of the control circuit terminal block cover, and then pull the cover towards you.
- (3) Hold both sides of the main circuit terminal block cover between thumb and forefinger and slide it towards you.
- (4) After performing wiring, mount the main circuit terminal block cover and control circuit terminal block cover in the reverse order of removal.

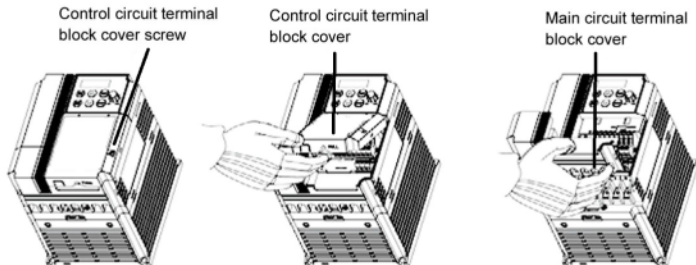

[Removing the Terminal Block Covers]

3.2 Terminal arrangement and screw specifications

The figures below show the arrangement of the main and control circuit terminals which differ according to inverter type. The two terminals prepared for grounding, which are indicated by the symbol  G in Figures A to C, make no distinction between the power supply side (primary circuit) and the motor side (secondary circuit).

(1) Arrangement of the main circuit terminals

Table 3.1 Main Circuit Terminals

Power supply voltage	Nominal Applied motor(kW)	Inverter type	Terminal screw size	Tightening torque (N·m)	Refer to:
Three- phase 400 V	0.4	U1-0040-4	M4	1.2	Fig A
	0.75	U1-0075-4			
	1.5	U1-0150-4			
	2.2	U1-0220-4			
	3.7	U1-0370-4			
Single- phase 200 V	0.4	U1-0040-7	M3	0.5	Fig B
	0.75	U1-0075-7			
	1.5	U1-0150-7	M4	1.2	Fig C
	2.2	U1-0220-7			

Figure A

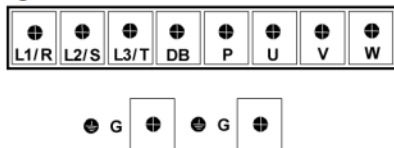

Figure B

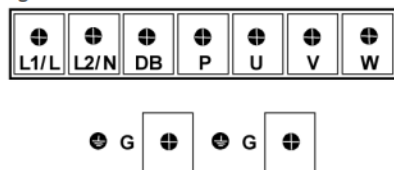
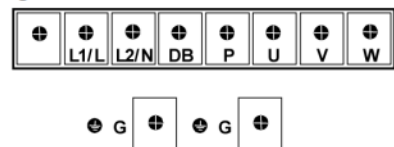

Figure C



(2) Arrangement of the control circuit terminals (common to all iMaster-U1 models)

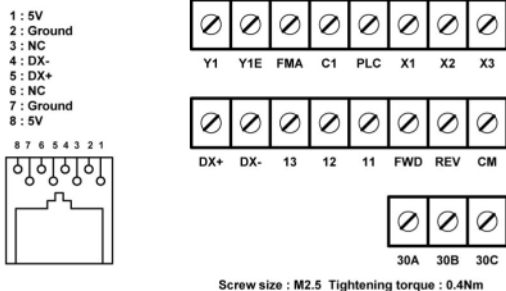

Table 3.2 Control Circuit Terminals

Terminal symbol	Screwdriver (Shape of tip, B x A) Thickness of tip: B	Allowable wire size	Bare wire length	Ferrule terminal* Opening dimension in the terminal block
First row in the box [Y1]~[X3]	Flat screwdriver (0.6 x 3.5 mm)	AWG22 to AWG14 (0.34 to 2.1 mm ²)	4.5 to 5 mm	5 (W) x 2.5 (H) mm
Other than the above	Flat screwdriver (0.6 x 3.5 mm)	AWG24 to AWG14 (0.25 to 2.1 mm ²)	5 to 6 mm	2.3 (W) x 2.5 (H) mm

Table 3.3 Recommended Ferrule Terminals

Screw size	Wire size	Type (216-)			
		With insulated collar		Without insulated collar	
		Short type	Long type	Short type	Long type
M2 or M2.5	AWG22 (0.34 mm ²)	322	302	152	132
	AWG20 (0.50 mm ²)	221	201	121	101
	AWG18 (0.75 mm ²)	222	202	122	102

The length of bared wires to be inserted into ferrule terminals is 5.0 mm or 8.0 mm for the short or long type, respectively.

The following crimping tool is recommended: Variocrimp 4 (Part No. 206-204).

3.3 Recommended wire sizes

Table 2.6 lists the recommended wire sizes. The recommended wire sizes for the main circuit terminals for an ambient temperature of 50°C are indicated for two types of wire: HIV single wire (for the maximum allowable temperature 75°C).

Table 3.4 Recommended Wire Sizes

Power supply voltage	Nominal applied motor (kW)	Inverter type	*1 Recommended wire size (mm ²)			Control circuit
			Main			
			Main circuit power input [L1/R, L2/S, L3/T] [L1/L, L2/N] Grounding [G]	Inverter output [U, V, W]	Braking resistor [P, DB]	
Three-phase 400 V	0.4	U1-0040-4	2.0(2.0)			0.5
	0.75	U1-0075-4				
	1.5	U1-0150-4				
	2.2	U1-0220-4				
	3.7	U1-0370-4				
Single-phase 200 V	0.4	U1-0040-7	2.0(2.0)	2.0(2.0)	2.0(2.5)	
	0.75	U1-0075-7				
	1.5	U1-0150-7	2.0(3.5)			
	2.2	U1-0220-7	5.5(5.5)			

*1 Use crimp terminals covered with an insulated sheath or insulating tube. Recommended wire sizes are for HIV/IV (PVC in the EU).

⚠ WARNING ⚠

To prevent the risk of hazardous accidents that could be caused by damage of the inverter, install the specified MCCB in the supply side (primary side) according to the following tables.

- Breaking capacity: Min. 10 kA
- Rated voltage: Min. 500 V

Power supply voltage	Applicable motor rating (kW)	Inverter type	Fuse Rating (A)	Rated Current(A) of MCCB (w/o DCR)
Three-phase 400 V	0.4	U1-0040-4	3	6
	0.75	U1-0075-4	6	
	1.5	U1-0150-4	10	10
	2.2	U1-0220-4	15	15
	3.7	U1-0370-4	20	20
Single-phase 200 V	0.4	U1-0040-7	10	10
	0.75	U1-0075-7	15	15
	1.5	U1-0150-7	30	20
	2.2	U1-0220-7	40	35

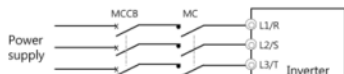

3.4 Wiring for main circuit terminals and grounding terminals

Follow the procedure below. Figure 3.1 illustrates the wiring procedure with peripheral equipment.

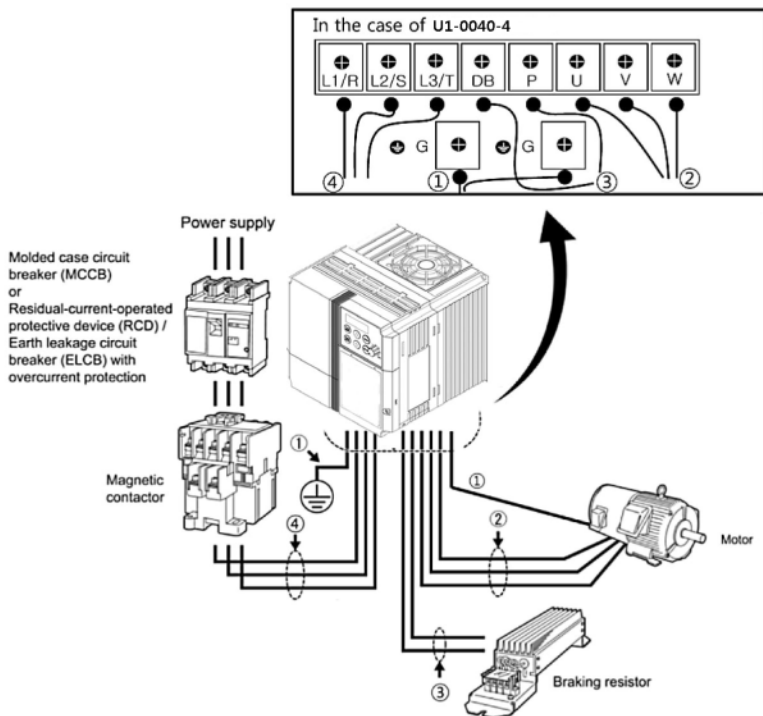
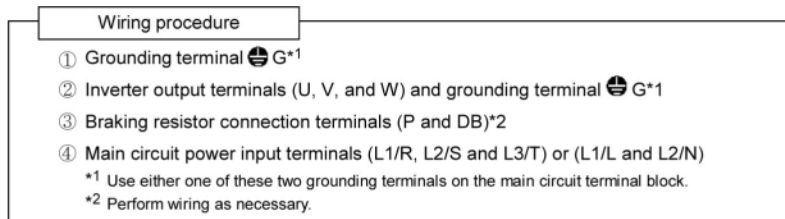

Figure 3.1 Wiring procedures for Peripheral Equipment

The wiring procedure for the U1-0040-4 is given below as an example. For other inverter types, perform wiring in accordance with their individual terminal arrangement.

① Grounding terminal (⚡G)

Be sure to ground either of the two grounding terminals for safety and noise reduction. It is stipulated by the Electric Facility Technical Standard that all metal frames of electrical equipment must be grounded to avoid electric shock, fire and other disasters.

Grounding terminals should be grounded as follows:

- 1) Ground the inverter in compliance with the national or local electric code.
- 2) Connect a thick grounding wire with a large surface area. Keep the wiring length as short as possible.

② Inverter output terminals, U, V, W and grounding terminal (⚡G)

- 1) Connect the three wires of the three-phase motor to terminals U, V, and W, aligning phases each other.
- 2) Connect the grounding wire of terminals U, V, and W to the grounding terminal (⚡G).

Note

- The wiring length between the inverter and motor should not exceed 50 m. If it exceeds 50 m, it is recommended that an output circuit filter (option) be inserted.
- Do not use one multicore cable to connect several inverters with motors.

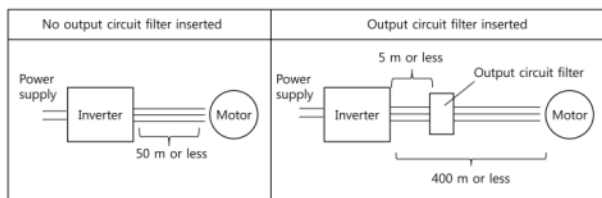

Note

- Do not connect a phase-advancing capacitor or surge absorber to the inverter's output lines (secondary circuit).
- If the wiring length is long, the stray capacitance between the wires will increase, resulting in an outflow of the leakage current. It will activate the overcurrent protection, increase the leakage current, or will not assure the accuracy of the current display. In the worst case, the inverter could be damaged.
- If more than one motor is to be connected to a single inverter, the wiring length should be the total length of the wires to the motors.

Note

- Driving 400 V series motor
- If a thermal relay is installed in the path between the inverter and the motor to protect the motor from overheating, the thermal relay may malfunction even with a wiring length shorter than 50 m. In this situation, add an output circuit filter (option) or lower the carrier frequency (Function code F26: Motor sound (Carrier frequency)).
- If the motor is driven by a PWM-type inverter, surge voltage that is generated by switching the inverter component may be superimposed on the output voltage and may be applied to the motor terminals. Particularly if the wiring length is long, the surge voltage may deteriorate the insulation resistance of the motor. Consider any of the following measures.
 - Use a motor with insulation that withstands the surge voltage.
 - Connect an output circuit filter (option) to the output terminals (secondary circuits) of the inverter.
 - Minimize the wiring length between the inverter and motor (10 to 20 m or less).

③ Braking resistor terminals, P and DB

- 1) Connect terminals P and DB of a braking resistor (option) to terminals P and DB on the main circuit terminal block.
- 2) Arrange the inverter and braking resistor to keep the wiring length to 5 m or less and twist the two wires or route them together in parallel.

④ Main circuit power input terminals, L1/R, L2/S, and L3/T (for three-phase voltage input) or L1/L and L2/N (for single-phase voltage input)

- 1) For safety, make sure that the molded case circuit breaker (MCCB) or magnetic contactor (MC) is turned off before wiring the main circuit power input terminals.
- 2) Connect the main circuit power supply wires (L1/R, L2/S and L3/T or L1/L and L2/N) to the input terminals of the inverter via an MCCB or residual-current-operated protective device (RCD)/earth leakage circuit breaker (ELCB)*, and MC if necessary.

It is not necessary to align phases of the power supply wires and the input terminals of the inverter with each other.

* With overcurrent protection

Tip

It is recommended that a magnetic contactor be inserted which can be manually activated.

This is to allow you to disconnect the inverter from the power supply in an emergency (e.g., when the protective function is activated) so as to prevent a failure or accident from causing the secondary problems.

4. Names and Functions of Keypad Components

As shown in the figure at right, the keypad consists of a four-digit 7-segment LED monitor, a potentiometer (POT), and six keys.

The keypad allows you to start and stop the motor, monitor running status, configure the function code data, check I/O signal states, and display maintenance information and alarm information.

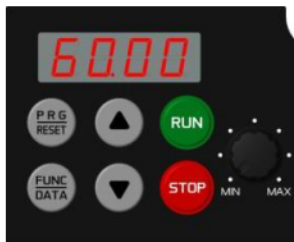









Table 4.1 Names and Functions of Keypad Components

Monitor, Potentiometer and Keys	Functions
	Four-digit, 7-segment LED monitor which displays the following according to the operation modes*. In Running mode: Running status information (e.g., output frequency, current, and voltage) In Programming mode: Menus, function codes and their data In Alarm mode: Alarm code which identifies the error factor if the protective function is activated.
	Potentiometer (POT) which is used to manually set a reference frequency, auxiliary frequencies 1 and 2 or PID process command.
	RUN key. Press this key to run the motor.
	STOP key. Press this key to stop the motor.
	UP/DOWN keys. Press these keys to select the setting items and change the function code data displayed on the LED monitor.
	Program/Reset key which switches the operation modes* of the inverter. In Running mode: Pressing this key switches the inverter to Programming mode. In Programming mode: Pressing this key switches the inverter to Running mode. In Alarm mode: Pressing this key after removing the error factor switches the inverter to Running mode.
	Function/Data key which switches the operation you want to do in each mode as follows: In Running mode: Pressing this key switches the information to be displayed concerning the status of the inverter (output frequency, output current, output voltage, etc.). In Programming mode: Pressing this key displays the function codes and sets their data entered with the ▲ and ▼ keys or the POT. In Alarm mode: Pressing this key displays detailed alarm information.

* iMaster-U1 features three operation modes: Running, Programming, and Alarm.

5. If an Alarm Code Appears on the LED Monitor

Quick reference table of alarm codes

Alarm code	Name	Alarm code	Name
OC1	Instantaneous overcurrent	dbH	Braking resistor overheated
OC2		OL1	Motor 1 overload
OC3		OLU	Inverter overload
OU1	Overvoltage	Er1	Memory error
OU2		Er2	Keypad communications error
OU3		Er3	CPU error
LU	Undervoltage	Er6	Operation protection
Lin	Input phase loss	Er7	Tuning error
OPL	Output phase loss	Er8	RS-485 communications error
OH1	Heat sink overheat	ErF	Data saving error during under voltage
OH2	External alarm	Err	Mock alarm
OH4	Motor protection (PTC thermistor)	CoF	PID feedback wire break

6. Specifications

6.1 Single-phase 200 V class series

Item		Specifications				
Type		0.4	0.75	1.5	2.2	
Applicable motor rating (kW) *1		0.4	0.75	1.5	2.2	
Output Ratings	Rated capacity (kVA) *2	0.9	1.6	2.8	3.8	
	Rated voltage (V) *3	Three-phase, 200 to 240 V (with AVR function)				
	Rated current (A) *4	3.5 (2.5)	4.2 (4.2)	9.2 (7.5)	10.0 (10.0)	
	Overload capability	150% of rated output current for 1 min or 200% of rated output current for 0.5 s (for the rated current given in parentheses)				
	Rated frequency (Hz)	50/60 Hz				
Input Ratings	Phases, voltage, frequency	Single-phase, 200 to 240 V, 50/60 Hz				
	Voltage and frequency variations	Voltage: +10 to -10%, Frequency: +5 to -5%				
	Rated current(A) *6	(w/o DCR)	5.4	9.7	16.4	24.0
	Required power supply capacity (kVA)	0.7	1.3	2.4	3.5	
Braking	Torque (%) *8	100		50	30	
	DC braking	Braking starting frequency*9: 0.0 to 60.0 Hz, Braking time: 0.0 to 30.0 s, Braking level: 0 to 100%				
	Braking transistor	Built-in				
Applicable safety standards		UL61800-5-1, IEC 61800-5-1(under application)				
Enclosure		IP20 (IEC 60529), UL open type (UL50)				
Cooling method		Fan cooling				
Mass (kg)		0.6	0.6	1.0	1.0	

*1 Fuji 4-pole standard motors

*2 Refers to the rated capacity assuming the rated output voltage as 220 V.

*3 Output voltages cannot exceed the power supply voltage.

*4 The load shall be reduced so that the continuous operating current is the rated current in parentheses or less if the carrier frequency is set to 3 kHz or above or the ambient temperature exceeds 40°C.

*5 Interphase voltage unbalance(%) =
$$\frac{\text{Max. voltage (V)} - \text{Min. voltage (V)}}{3 - \text{phase average voltage (V)}} \times 67 \text{ (Refer to IEC 61800 - 3)}$$

If this value is 2 to 3%, use an optional AC reactor (ACR).

*6 Refers to the estimated value to apply when the power supply capacity is 500 kVA (inverter capacity x 10 when the inverter capacity exceeds 50 kVA) and the inverter is connected to the %X = 5% power supply.

*8 Refers to the average braking torque to apply when the motor running alone decelerates from 60 Hz with the AVR control being OFF. (It varies with the efficiency of the motor.)

*9 Available only for induction motor drive.

6.2 Three-phase 400 V class series

Item		Specifications					
Type		0.4	0.75	1.5	2.2	3.7	
Applicable motor rating (kW) *1		0.4	0.75	1.5	2.2	3.7	
Output Ratings	Rated capacity (kVA) *2	1.1	1.9	3.2	4.1	6.8	
	Rated voltage (V) *3	Three-phase, 380 to 480 V (with AVR function)					
	Rated current (A)	1.8 (1.5)	2.5 (2.5)	4.3 (4.2)	6.3 (5.5)	10.5 (9.0)	
	Overload capability	150% of rated output current for 1 min or 200% of rated output current for 0.5 s (for the rated current given in parentheses)					
	Rated frequency (Hz)	50/60 Hz					
Input Ratings	Phases, voltage, frequency	Three-phase, 380 to 480 V, 50/60 Hz					
	Voltage and frequency variations	Voltage: +10 to -15% (Interphase voltage unbalance: 2% or less) *5, Frequency: +5 to -5%					
	Rated current (A) *6	(w/o DCR)	1.7	3.1	5.9	8.2	13.0
	Required power supply capacity (kVA)		0.6	1.1	2.0	2.9	4.9
Braking	Torque (%) *8	100		50	30		
	DC braking	Braking starting frequency*9: 0.0 to 60.0 Hz, Braking time: 0.0 to 30.0 s, Braking level: 0 to 100%					
	Braking transistor	Built-in					
Applicable safety standards		UL61800-5-1, IEC 61800-5-1 (under application)					
Enclosure		IP20 (IEC 60529), UL open type (UL50)					
Cooling method		Natural cooling			Fan cooling		
Mass (kg)		0.8	0.8	0.9	0.9	1.3	

*1 Fuji 4-pole standard motors

*2 Refers to the rated capacity assuming the rated output voltage as 440 V.

*3 Output voltages cannot exceed the power supply voltage.

*5 Interphase voltage unbalance(%) = $\frac{\text{Max. voltage (V)} - \text{Min. voltage (V)}}{3 - \text{phase average voltage (V)}} \times 67$ (Refer to IEC 61800 - 3)

If this value is 2 to 3%, use an optional AC reactor (ACR).

*6 Refers to the estimated value to apply when the power supply capacity is 500 kVA (inverter capacity x 10 when the inverter capacity exceeds 50 kVA) and the inverter is connected to the %X = 5% power supply.

*8 Refers to the average braking torque to apply when the motor running alone decelerates from 60 Hz with the AVR control being OFF. (It varies with the efficiency of the motor.)

*9 Available only for induction motor drive.

7. Connection diagram in operation by external signal inputs

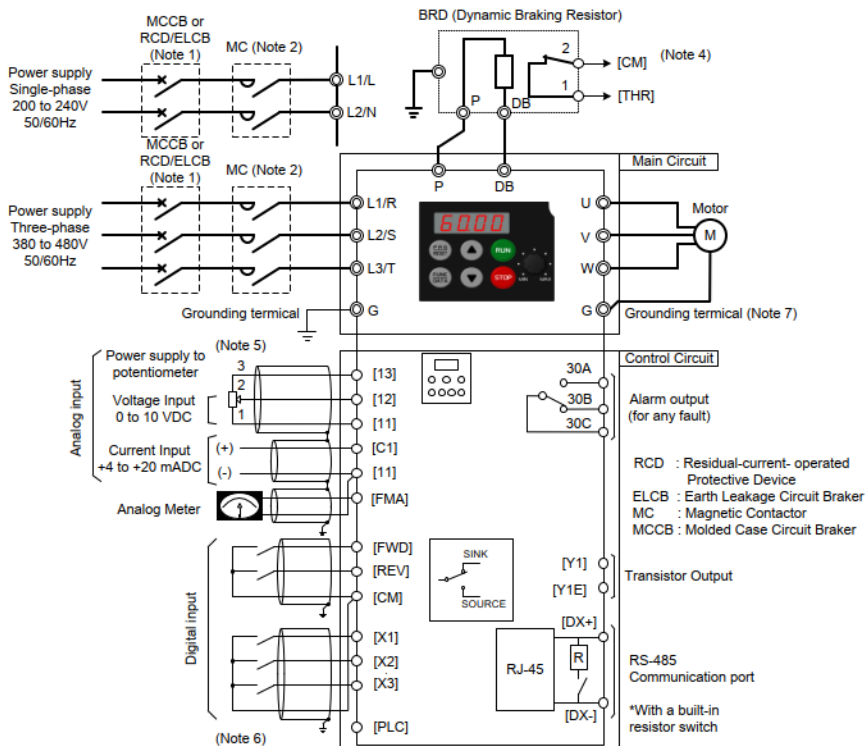

(Note 1) Install a recommended molded case circuit breaker (MCCB) or a residual-current-operated protective device (RCD)/earth leakage circuit breaker (ELCB) (with overcurrent protection) in the primary circuit of the inverter to protect wiring. Do not use an MCCB or RCD/ELCB whose capacity exceeds the recommended rated current.

(Note 2) A magnetic contactor (MC) should, if necessary, be mounted independent of the MCCB or ELCB to cut off the power fed to the inverter. MCs or solenoids that will be installed close to the inverter require surge absorbers to be connected in parallel to their coils.

(Note 4) The THR function can be used by assigning "9" (External alarm) to any of terminals [X1] to [X3],[FWD] or [REV] (function code E01 to E03, E98, or E99).

(Note 5) Frequency can be set by connecting a frequency setting device (external potentiometer) between terminals [11], [12] and [13] instead of inputting voltage signal (0 to +10 VDC or 0 to +5VDC) between terminals [12] and [11].

(Note 6) For the wiring of the control circuit, use shielded or twisted wires. When shielded wires are used, connect the shields to earth. To prevent malfunction due to noise, keep the control circuit wiring away from the main circuit wiring as far as possible (recommended: 10 cm or longer), and never set them in the same wire duct. When crossing the control circuit wiring with the main circuit wiring, set them at right angles.

8. External Dimensions

[unit: mm]

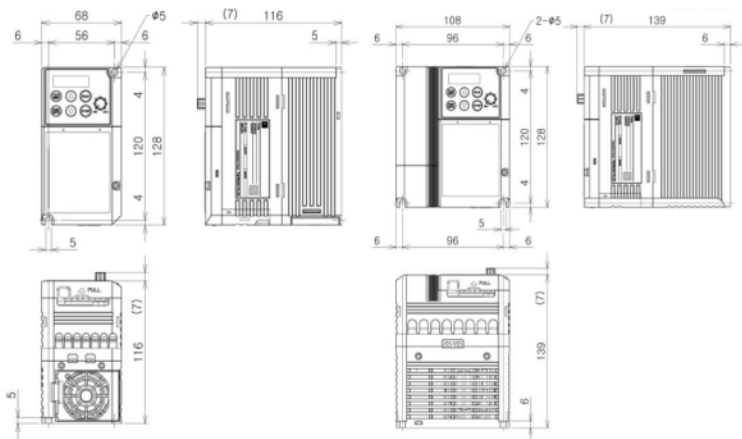

[U1-0040-7/U1-0075-7]

[U1-0150-7/U1-0220-7/
U1-0040-4~U1-0220-4]

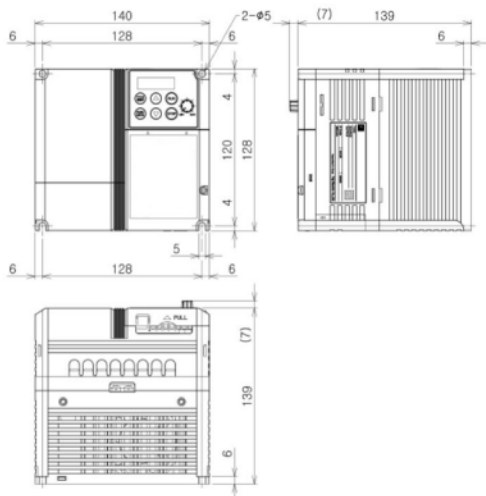

[U1-0370-4]

9. Function Code Tables







Function codes enable the iMaster-U1 of inverters to be set up to match your system requirements.

Each function code consists of a 3-letter alphanumeric string. The first letter is an alphabet that identifies its group and the following two letters are numerals that identify each individual code in the group. The function codes are classified into seven groups: Fundamental Functions (F codes), Extension Terminal Functions (E codes), Control Functions (C codes), Motor 1 Parameters (P codes), High Performance Functions (H codes), Application Functions (J codes) and Link Functions (y codes). To determine the property of each function code, set data to the function code.

(This manual only shows F functions, refer to the instruction on website for more functions.)

Changing, validating, and saving function code data when the motor is running

Function codes are indicated by the following based on whether they can be changed or not when the inverter is running:

Notation	Change when running	Validating and saving function code data
Y*	Possible	If the data of the codes marked with Y* is changed, the change will immediately take effect; however, the change is not saved into the inverter's memory. To save the change, press the  key. If you press the  key without pressing the  key to exit the current state, then the changed data will be discarded and the previous data will take effect for the inverter operation.
Y	Possible	The data of the codes marked with Y can be changed with the  and  keys regardless of whether the motor is running or not. Pressing the  key will make the change effective and save it into the inverter's memory.
N	Impossible	—

Using negative logic for programmable I/O terminals

The negative logic signaling system can be used for digital input terminals and transistor output terminals by setting the function code data specifying the properties for those terminals. Negative logic refers to the inverted ON/OFF (logical value 1 (true)/0 (false)) state of input or output signal. An active-ON signal (the function takes effect if the terminal is short-circuited.) in the normal logic system is functionally equivalent to active-OFF signal (the function takes effect if the terminal is opened.) in the negative logic system. An active-ON signal can be switched to active-OFF signal, and vice versa, with the function code data setting.

To set the negative logic system for an input or output terminal, enter data of 1000s (by adding 1000 to the data for the normal logic) in the corresponding function code.

Example: "Coast to a stop" command BX assigned to any of digital input terminals [X1] to [X3] using any of function codes E01 through E03.

Function code data	BX
7	Turning BX ON causes the motor to coast to a stop. (Active ON)
1007	Turning BX OFF causes the motor to coast to a stop. (Active OFF)

Limitation of data displayed on the LED monitor

Only four digits can be displayed on the 4-digit LED monitor. If you enter more than 4 digits of data valid for a function code, any digits after the 4th digit of the set data will not be displayed; however they will be processed correctly.

The following tables list the function codes available for the iMaster-U1 inverters.

F codes: Fundamental Functions

Code	Name	Data setting range	Increment	Unit	Change when running	Data copying	Default setting
F00	Data Protection	0: Disable both data protection and digital reference protection 1: Enable data protection and disable digital reference protection 2: Disable data protection and enable digital reference protection 3: Enable both data protection and digital reference protection	-	-	Y	Y	0
F01	Frequency Command 1	0: UP/DOWN keys on keypad 1: Voltage input to terminal [12] (0 to +10VDC) 2: Current input to terminal [C1] (4 to 20 mA DC) 3: Sum of voltage and current inputs to terminals [12] and [C1] 4: Built-in potentiometer (POT) 7: Terminal command UP/DOWN control	-	-	N	Y	4
F02	Operation Method	0: RUN/STOP keys on keypad (Motor rotational direction specified by terminal command FWD/REV) 1: Terminal command FWD or REV 2: RUN/STOP keys on keypad (forward) 3: RUN/STOP keys on keypad (reverse)	-	-	N	Y	2
F03	Maximum Frequency 1	25.0 to 400.0	0.1	Hz	N	Y	60.0
F04	Base Frequency 1	25.0 to 400.0	0.1	Hz	N	Y	60.0
F05	Rated Voltage at Base Frequency 1	0: Output a voltage in proportion to input voltage 80 to 240: Output an AVR-controlled voltage (for 200 V class series) 160 to 500: Output an AVR-controlled voltage (for 400 V class series)	1	V	N	Y2	0
F06	Maximum Output Voltage 1	80 to 240: Output an AVR-controlled voltage (for 200 V class series) 160 to 500: Output an AVR-controlled voltage (for 400 V class series)	1	V	N	Y2	200 (400)
F07	Acceleration Time 1	0.00 to 3600 Note: Entering 0.00 cancels the acceleration time, requiring external soft-start.	0.01	s	Y	Y	6.00
F08	Deceleration Time 1	0.00 to 3600 Note: Entering 0.00 cancels the deceleration time, requiring external soft-start.	0.01	s	Y	Y	6.00
F09	Torque Boost 1	0.0 to 20.0 (percentage with respect to "F05: Rated Voltage at Base Frequency 1") Note: This setting takes effect when F37 = 0	0.1	%	Y	Y	See Table A.

(F codes continued)

Code	Name	Data setting range	Increment	Unit	Change when running	Data copying	Default setting
F10	Electronic Thermal Overload Protection for Motor 1 (Motor characteristics)	1: For a general-purpose motor with shaft-driven cooling fan 2: For an inverter-driven motor with separately powered cooling fan	-	-	Y	Y	1
F11	(Overload detection level)	0.00: Disable, 0.01 to 100.0 1 to 135% of the rated current (allowable continuous drive current) of the motor	0.01	A	Y	Y1 Y2	See Table A.
F12	(Thermal time constant)	0.5 to 75.0	0.1	min	Y	Y	5.0
F14	Restart Mode after Momentary Power Failure (Mode selection)	0: Disable restart (Trip immediately) 1: Disable restart (Trip after a recovery from power failure) 2: Trip after decelerate-to-stop *2 4: Enable restart (Restart at the frequency at which the power failure occurred, for general loads) 5: Enable restart (Restart at the starting frequency)	-	-	Y	Y	1
F15	Frequency Limiter (High)	0.0 to 400.0	0.1	Hz	Y	Y	70.0
F16	(Low)	0.0 to 400.0	0.1	Hz	Y	Y	0.0
F18	Bias(Frequency command 1)	-100.00 to 100.00 *1	0.01	%	Y*	Y	0.00
F20	DC Braking 1 (Braking starting frequency)	0.0 to 60.0	0.1	Hz	Y	Y	0.0
F21	(Braking level)	0 to 100 *2	1	%	Y	Y	0
F22	(Braking time)	0.00 (Disable), 0.01 to 30.00	0.01	s	Y	Y	0.00
F23	Starting Frequency	0.1 to 60.0	0.1	Hz	Y	Y	1.0
F24	(Holding time)	0.00 to 10.00	0.01	s	Y	Y	0.00
F25	Stop Frequency	0.1 to 60.0	0.1	Hz	Y	Y	0.2
F26	Motor Sound (Carrier frequency)	0.75 to 16	1	kHz	Y	Y	2
F27	(Tone)	0: Level 0 (Inactive) 1: Level 1	-	-	Y	Y	0
F30	Analog Output [FMA] (Voltage adjustment)	0 to 300	1	%	Y*	Y	100
F31	(Function)	Select a function to be monitored from the followings. 0: Output frequency 1 (before slip compensation) 1: Output frequency 2 (after slip compensation) 2: Output current 3: Output voltage 7: PID feedback amount (PV) 9: DC link bus voltage 14: Calibration 15: PID command (SV) 16: PID output (MV)	-	-	Y	Y	0

(F codes continued)

Code	Name	Data setting range	Increment	Unit	Change when running	Data copying	Default setting
F37	Load Selection/Auto Torque Boost	0: Variable torque load 1: Constant torque load 2: Auto-torque boost	-	-	N	Y	1
F39	Stop Frequency (Holding Time)	0.00 to 10.00	0.01	s	Y	Y	0.00
F42	Control Mode Selection 1	0: V/f control with slip compensation inactive 1: Dynamic torque vector control 2: V/f control with slip compensation active	-	-	N	Y	0
F43	Current Limiter (Mode selection)	0: Disable (No current limiter works.) 1: Enable at constant speed (Disable during ACC/DEC) 2: Enable during ACC/constant speed operation	-	-	Y	Y	2
F44	(Level)	20 to 180 (The data is interpreted as the rated output current of the inverter for 100%.) *2	1	%	Y	Y	180
F50	Electronic Thermal Overload Protection for Braking Resistor (Discharging capability)	1 to 900, OFF (Cancel)	1	kWs	Y	Y1 Y2	OFF
F51	(Allowable average loss)	0.001 to 50.00	0.001	kW	Y	Y1 Y2	0.001

*1 When you make settings from the keypad, the incremental unit is restricted by the number of digits that the LED monitor can display. (Example) If the setting range is from -200.00 to 200.00, the incremental unit is:

"1" for -200 to -100, "0.1" for -99.9 to -10.0 and for 100.0 to 200.0, and "0.01" for -9.99 to -0.01 and for 0.00 to 99.99.

*2 The percentage is relative to the rated output current.